



CustomControlSensors

# Non-Hazardous Areas Pre-Set Pressure Switch

## 674D\* - Diaphragm Sensor

### DESCRIPTION

- Highly reliable devices utilizing the CCS Dual-Snap® Belleville disc spring principle pioneered by CCS' engineers .
- Engineering based on aerospace technology.
- Rigid, midsize and internally adjustable for factory setting.
- Repeatable and stable set points.
- Vibration and shock resistant.
- High cycle life.
- High over-pressure capability. (System and Proof)

### SERIES:

674D\*

### SET POINT RANGE:

#### DIFFERENTIAL PRESSURE:

2 to 800 PSID  
0.14 to 55.16 bar  
13.8 to 5515 kPa

### OPERATING TEMPERATURE:

Temperature limits change with o-ring selection.

-40° to 186°F  
-40° to 86°C

### STANDARD FEATURES:

- CE Mark
- CCC
- CRN
- NEMA: 4,13 / IP66
- Weatherproof



SHIPPING WEIGHT: APPROXIMATELY 45 OUNCES (1275 GRAMS)

### INSTALLATION DRAWING

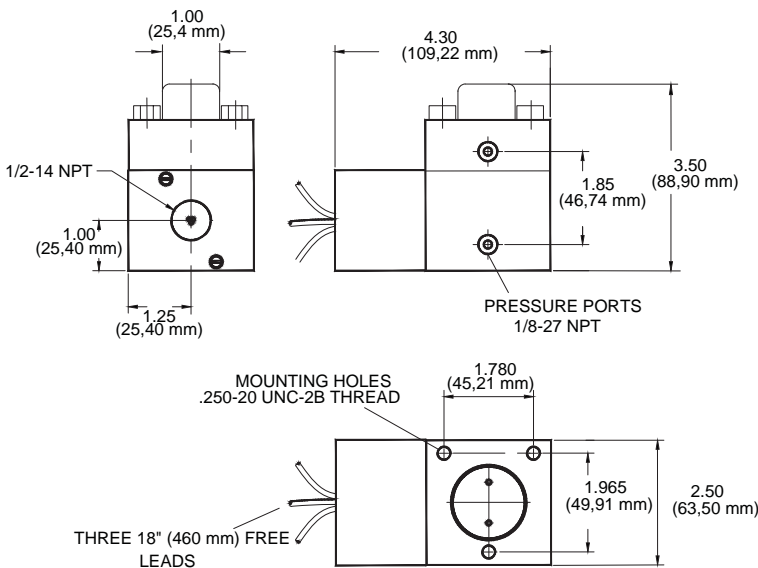

### DESIGN PRINCIPLES

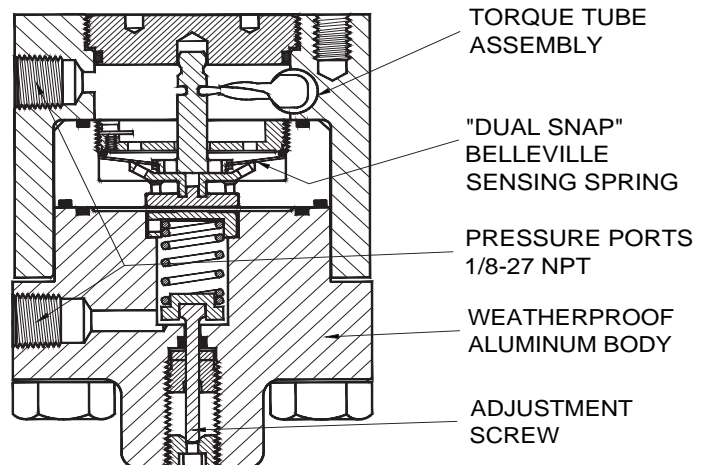

SERIES 674D

**FIELD SETTING:** Loosen access cover. Adjust screwdriver adjustment slot. Clockwise to decrease settings. Counterclockwise to increase settings.

**NOTE:** DO NOT USE ELECTRICAL HEX FOR TORQUING.



CustomControlSensors

# Non-Hazardous Areas Pre-Set Pressure Switch

## 674D\* - Diaphragm Sensor

### OPERATING AND ORDERING DATA

SERIES 674D*	WETTED PARTS: 1/8"-27 NPT ALUMINUM PRESSURE PORT & POLYIMIDE DIAPHRAGM, VITON O-RING							
	FIX SET POINT RANGE (SPECIFY SET POINT ON ORDER)		APPROXIMATE DEAD BAND PSI (BAR)		MAX SYSTEM PRESSURE PSIG (BAR)	PROOF PRESSURE PSIG (BAR)		
	INCREASING PRESSURE PSID (BAR)	DECREASING PRESSURE PSID (BAR)	AT BOTTOM OF RANGE	AT TOP OF RANGE		BOTH PORTS SIMULT.	HIGH OVER LOW LOW OVER	
					HIGH		LOW	
674D*1	5-80 (0.34-5.52)	2-68 (0.14-4.68)	3 (0.21)	12 (0.83)	3000 (207)	4500 (310)	2500 (172)	2500 (172)
674D*2	81-350 (5.58-24.13)	67-297 (4.62-20.48)	14 (.97)	53 (3.65)				
674D*3	351-800 (24.2-55.15)	299-680 (20.61-46.88)	60 (4.13)	120 (8.27)				

### HOW TO ORDER

Follow these steps to build your part number:

1. Specify the series based on your required set point, range, dead band, system pressure and proof pressure.
2. Add desired options model code letter.
3. Add the applicable standard suffix number.

(Ex: 674DF1-7008)

### PRESSURE CONVERSION

1 BAR = 14.5 PSI  
1 kPa = 0.145 PSI

### OPTIONAL STANDARD MODIFIED SUFFIXES

7008: Gold Contacts

### CERTIFICATIONS

Consult CCS website for complete certification and approval listing.

### ELECTRICAL CHARACTERISTICS

RATING OF SWITCH ELEMENT

VOLTS	AMPERES	
	SPDT	Res.
125 AC - 50/60 Hz	15	
250 AC - 50/60 Hz	15	
480 AC - 50/60 Hz	15	
250 DC	.2	
125 DC	.5	
28 DC	2	
*125 AC	1 max	
*30 DC	1 max	
*Gold Contacts -7008 Suffix		

### OPTIONS MODEL CODES

F: Ethylene Propylene O-Ring

*Note: Additional modified standard suffixes are available, consult CCS sales department or CCS Representative.*

### SCHEMATIC AND WIRING CODE

