

Product Data Sheet  
118DS-11b  
11/14/03

## 624 II Pneumatic Control Units

For automatically controlling temperature, pressure, differential pressure, flow, liquid level, and humidity.

### Features

- **Excellent Frequency Response**  
Far better than most comparable units.
- **Low Air Consumption**  
Non-bleed pilot
- **Easy Maintenance and Interchangeability**  
Plug-in units, simple to work and calibrate
- **Long Life**  
All working parts of aluminum or stainless steel. No copper bearing alloys  
Rugged construction
- **Stability**  
Highly stable – high pilot valve capacity
- **Gain Control**  
50-.25 or 100-2..5, Easily adjustable
- **Integral (Reset) Model**  
Adjustable from less than .01 to 85 repeats per minute
- **Derivative Control**  
Action adjustable from 0 to 30 minutes. (Derivative by-pass standard)
- **Easily Reversible Control Action**  
Just turn a cover plate
- **High Capacity Pilot**  
Flow is well over 3 scfm at 1 psi drop, both exhaust and delivery
- **Push Button Restriction Cleaner**
- **No Plastic Tubing**

624 II control units are available in the following control modes.

Gain (Proportional)

Gain + Integral + Derivative (P + R + D)

Differential Gap (Direct Set)

With remote feedback

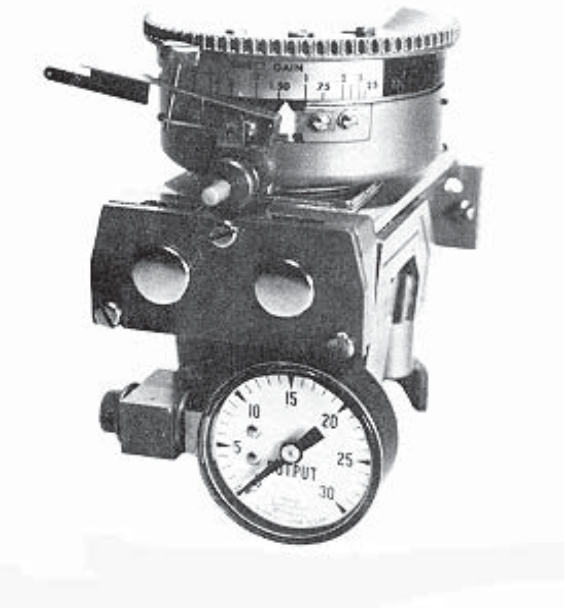

Figure 1 - 624 II Control Unit with gain (proportional)

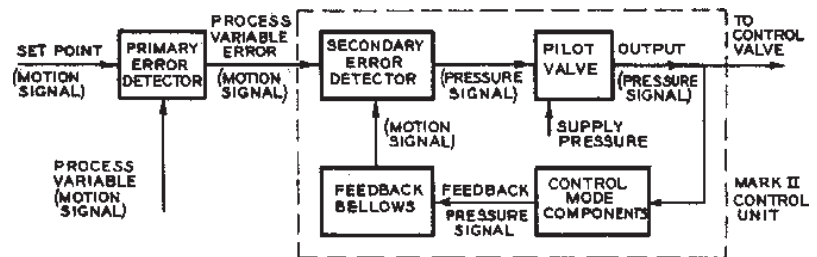

Figure 2 - Block Diagram of 624 II Control Units

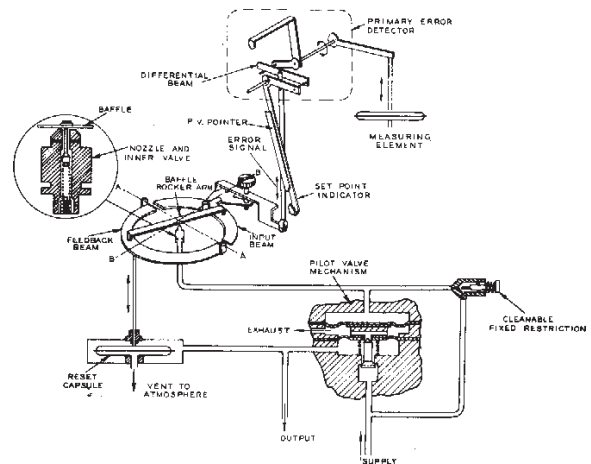

Figure 3 - Schematic of Control Unit with gain control

### Gain Control

Figure 2 shows major components of the 624 II control unit with the interconnecting signals between components. The proportional control mechanism is schematically illustrated in Figure 3.

### Primary Error Detector

As outlined in Figure 3 the primary error detector is not part of the 624 II control unit, but is part of the pointer mounting assembly. The differential beam of the assembly moves to give a motion error-signal proportional to the deviation of the measured variable from setpoint. This error signal is fed into the input level arm on the 624 II control unit.

### Adjustable Gain – Secondary Error Detector

The input lever moves a “C” shaped input beam that is pivoted along the axis B-B. Also, a “C” shaped feedback beam is pivoted along the A-A axis by the feedback capsular element. The baffle rocker-arm is pivoted on the two beams which are arranged to form a circle. Rotating the baffle rocker-arm will place its pivot points anywhere on it’s circle.

When the pivot points are close to the B-B axis, the input motion is at a minimum and the feedback motion to the baffle is at a maximum, thus providing low gain or a wide proportional band (approximately 400% band or .25 gain).

When the pivot points are close to the A-A axis, the input motion is at a maximum and the feedback motion to the baffle is at a minimum. This provides high gain or a narrow proportional band (approximately 2% or gain of 50). Because the drum-type cover of the 624 II control unit is attached to the baffle rocker-arm, rotating the cover will rotate the baffle rocker-arm and change the gain of the controller. Position of the drum scale to the pointer (shown in figure 1) indicates the setting.

Moving the pivot point across the B-B axis changes the unit from direct to reverse acting.

### Non-bleed Pilot Valve

The pilot valve which senses the nozzle back pressure is standard non-bleed type, and has a proven history for reliability. It has high capacity with bal-

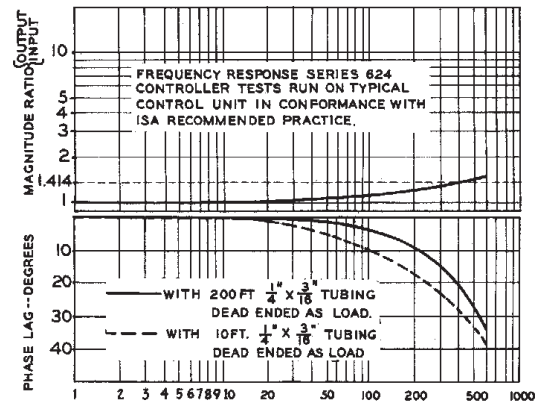

Figure 4 - Frequency response of the control unit

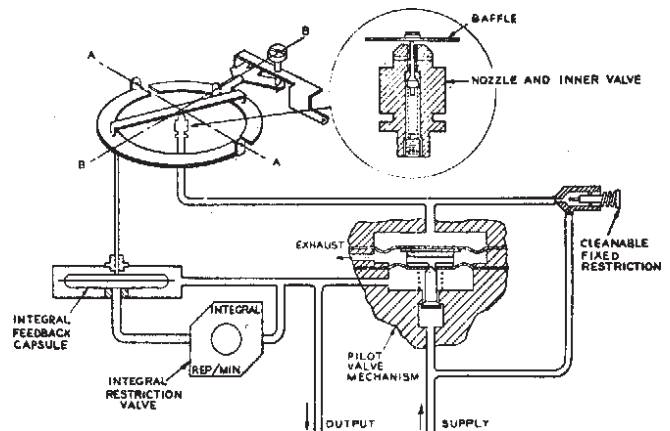

Figure 5 - Schematic of the gain + integral 624 II unit with internal feedback

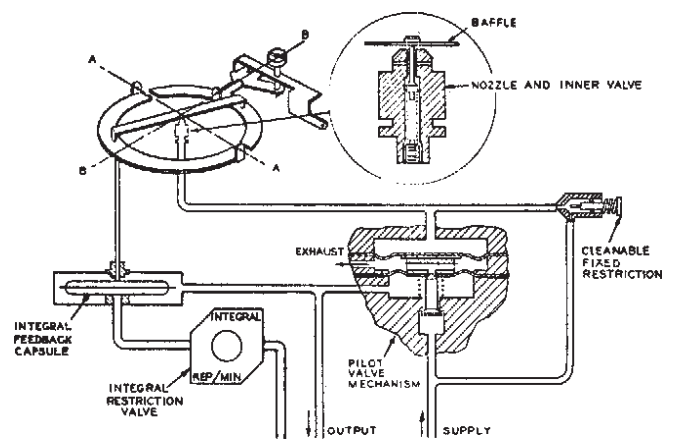

Figure 6 - Schematic of gain + integral 624 II unit with external feedback

anced supply and exhaust characteristics, and provides fast response with economy in air consumption. Large supply and output connections to the 624 II unit and the instrument case enable the full pilot valve capacity to be utilized to the control valve.

### Feedback Element

The capsular element is made of Ni-Span-C\* for thermal stability, with a push-rod connection to transfer the feedback motion to the feedback beam. Referring to figure 3, it can be seen that the feedback element camber is part of the output chamber of the pilot valve.

### Materials of Construction

The basic 624 II control unit is made of no copper-bearing cast aluminum. Most working parts are made of stainless steel or aluminum. The diaphragms in the pilot valve are reinforced neoprene.

### Frequency Response

Cut-off frequency is defined as the point where the gain ("magnitude ratio", "output/input") rises to 1.414 or drops to 0.7. From the frequency response curves in the upper half of Figure 4 it can be seen that that the cut-off frequency of the 624 II unit is approximately 300 to 400 cpm. The high cut-off frequency permits this controller to handle disturbances to the control loop that would upset or pass through slower-acting units. Thus a more constant value of the measured variable is maintained during upsets to the process.

### Gain + Integral Control

A schematic of the gain + integral feedback is shown in Figure 5. The only change in this unit from the gain unit is the addition of the integral valve. (Field addition) Where external feedback is required, the schematic of Figure 6 applies. Where anti-reset wind up is required, the schematic of Figure 7 applies. Anti-reset wind up and external feedback models cannot be added in the field.

### Feedback System

The integral feedback signal is fed to the inside of the feedback element through the integral valve. Proportional feedback pressure connects to the outside of the same element. This combined motion signal from the feedback element goes to the feedback beam of

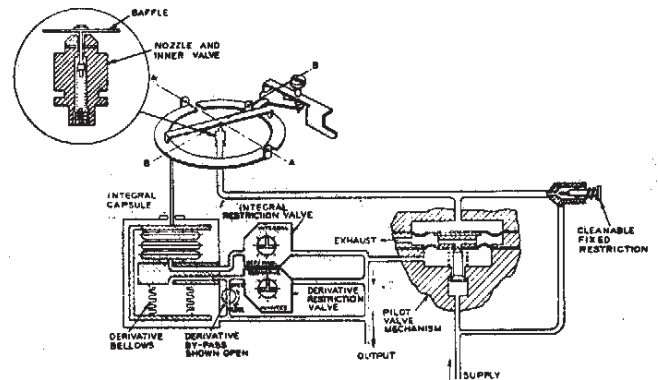

Figure 7 - Schematic of control unit with batch reset

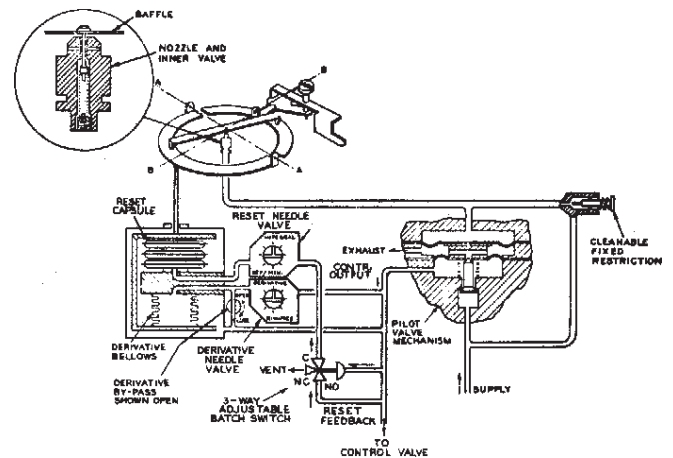

Figure 8 - Schematic of three-mode control unit

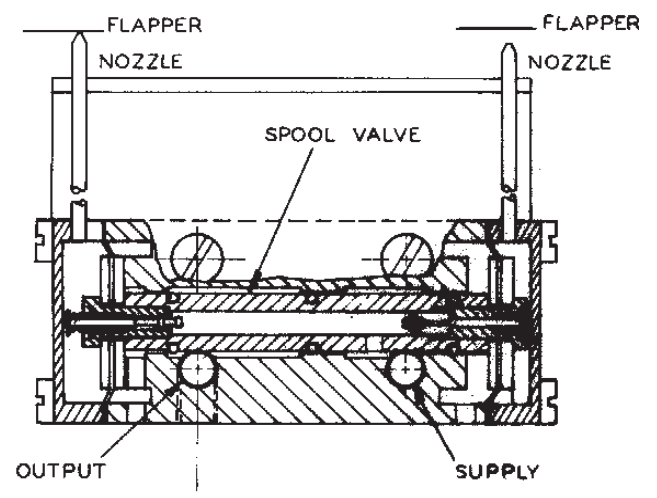

Figure 9 - Schematic of differential gap

the secondary error detector.

The reset needle-valve is a direct-reading type, and is continuously adjustable between .01 to 85 repeats per minute.

### Three Mode Control Gain + Integral + Derivative

Figure 8 schematically illustrates the three-mode control unit. In this unit, as in the integral unit, an inner valve and nozzle is used rather than the flapper nozzle of the derivative unit.

Two feedback elements are used in the three-mode controller, and are yoked together so that increasing internal pressures within the element cause opposing forces. Output pressure from the pilot valve passes through separate valves.

In Figure 8 the lower bellows initiates negative feedback response, since its action on the feedback pin opposes the initial signal change. The derivative needle-valve delays this negative feedback temporarily thereby producing derivative response.

Action of the upper capsule opposes the lower bellows motion and give positive feedback. The integral valve, by restriction the output pressure fed into the integral capsule, delays the positive feedback and reset action takes place.

When starting up a process with a three-mode controller, it is sometimes desirable to eliminate the derivative action without changing the derivative setting. For this reason, a derivative by-pass has been included which can be opened to eliminate derivative action, and closed to restore the action.

### Differential Gap Control Direct Set

Figure 9 schematically illustrates the differential gap control unit. This differential gap controller utilizes a new housing, made from low copper bearing alloys, and is located in the same area as the 624 II control units. The switching action is accomplished with a spool valve type mechanism, and positive locking done by a variable resistor.

“Differential-Gap” is defined as the range of values

through which the controlled variable must pass in order to change the on-off control output from maximum to zero or vice versa. It is commonly expressed in units of the scale, or in percentage of scale range.

### How It Works

The width of the differential-gap is set by manually adjusting the low and high limit pointers to the desired values. When the variable is below the low limit, the direct-acting controller output is zero, and remains zero until the variable rises to the high limit setting. At this point, the output becomes maximum, and remains so until the variable again reaches the low limit.

The limit pointers may be set at the ends of the scale for a 100% differential-gap, they may be placed touching each other to give on-off action with a differential-gap of ½%, or they may be adjusted for any differential-gap between ½% and 100%.

Maximum output of the controller is approximately 1/4 psi, less than the supply pressure. The standard instrument is designed for use with a nominal 20 psi supply pressure, but will work up to 60 psi.

# Bristol Babcock

## Pneumatic Control Units

Product Data Sheet  
118DS-11b  
11/14/03



Figure 10 - Gain + integral



Figure 12 - Differential gap

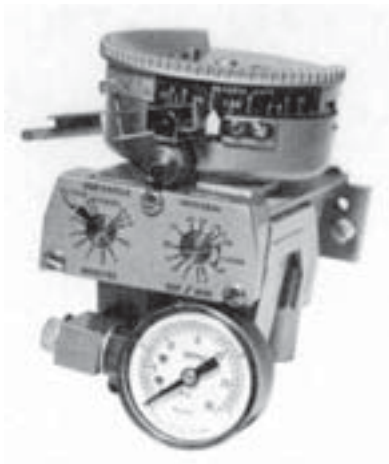

Figure 10 - Three mode

**U.S.A.**  
**Bristol Babcock Inc.**  
1100 Buckingham St.  
Watertown, CT 06795  
Telephone: (860) 945-2200  
Fax: (860) 945-2213

**U.K.**  
**Bristol Babcock Ltd.**  
Blackpole Road  
Worcestershire, DY11 7QP., England  
Telephone: 44-(0)-1905-856950  
Fax: 44-(0)-1905-856969

**Canada**  
**Bristol Babcock Canada**  
234 Attwell Drive  
Toronto, Ontario M9W 5B3  
Telephone: (416) 675-3820  
Fax: (416) 674-5129