

# Transducers

## Models 77 and 771 Current-to-Pneumatic Transducers

### Introduction

#### Features & Benefits

- ▶ High signal sensitivity for demanding applications or
- ▶ Simplified design ensures simplified operation
- ▶ Rugged, NEMA construction, with insensitivity to shock, vibration, and supply pressure variations accommodate operation in harsh industrial environments
- ▶ Choice of output capacities provides application versatility

#### Description

The Models 77 and 771 convert a DC millampere input signal to a pneumatic output signal directly proportional to the input. Their rugged design and ability to withstand shock and vibration allow them to be installed in even the harshest industrial environments. In addition, their exhaust can provide a light purge of the terminal enclosure by plugging the drain hole, making both the Model 77 and Series 771 suitable for use in corrosive environments.

#### Model 77 Current-to-Pneumatic Transducer

The Model 77 Current-to-Pneumatic Transducer, which was designed specifically for measuring circuits, converts the output of an electronic measuring device to a pneumatic signal for indication, recording, computation, or control. It can also be used to convert an electronic controller's signal to operate a final control element, such as a control valve circuit that requires a high degree of accuracy.

The Model 77 is typically used to signal a valve positioner. If it is used for direct-loading of valve actuators or other large volumes, a volume booster relay is required to minimize time lags and the effects of leakage.

#### Model 771 Current-to-Pneumatic Transducers

The Model 771 Current-to-Pneumatic Transducers were designed as a cost-effective valve service current-to-pneumatic transducer.

The Model 771 receives the output of an electronic signal, such as a PID control function, and drives a control valve via the transducer until the control function is satisfied. For measuring circuits, or for control circuits requiring a higher degree of transducing accuracy, the Model 77 should be used.

Because its boosted output capacity minimizes time lags and the effects of leakage, the Model 771B should be used for direct-loading of valve actuators or other large volumes. If the valve actuator includes a valve positioner, a Model 771S should be used.



#### Specifications – Model 77

##### Functional Specifications

##### Supply Pressure

20 psig,  $\pm 2$  psig for 3-15 psig output  
30 psig,  $\pm 2$  psig for 3-27 psig output

##### Input/Output Data

See Model Selection

##### Model 77

For general purpose and non-incendive applications

##### Model 77F

For intrinsically-safe applications

##### Zero Offset Adjustment

+40% and -20% of span

##### Pneumatic Connections

1/4" NPT

##### Output Capacity

0.16 scfm

##### Supply Pressure Effect

Less than 1% of span (change of output for supply change from 18 to 22 psig)

##### Temperature Range

-40 to 180°F (-40 to 85°C)

##### Electrical Connections

Enclosed terminal block, 1/2" threaded

# Transducers

## Models 77 and 771 Current-to-Pneumatic Transducers

### Technical data

#### Surface Mounting

Two 1/4 x 20 x 5/16" deep blind tapped holes

#### Enclosure

NEMA 3R  
NEMA 4 via conduit vent

#### Electrical Classification

FM Approved  
Model 77  
Non-incendive for Class I, Div. 2, Groups A, B, C, D.  
Dust-ignition proof for Class II, Div. 1, Groups E, F, G.  
Suitable for Class III, Div. 1 hazardous locations and NEMA 4.  
Model 77F  
Intrinsically safe for Class I/II/III, Div. 1, Groups A, B, C, D, E, F, G and NEMA 4 when used with approved barriers and converters listed on Moore drawing #15032-7704/7705, and when installed per manufacturer's instructions.

### Performance Specifications

#### Calibration Accuracy

±0.25% of span

#### Reproducibility

0.2% of span

#### Response Level

0.025% of span

### Specifications – Series 771

#### Functional Specifications

##### Supply Pressure

20 psig (35 psig for 771-8\_ \_ \_)

##### Input/Output Data

See Model Selection

##### Zero Offset Adjustment

+40% and -20% of span

##### Output Capacity

Standard: 0.16 scfm  
Boosted: 2.0 scfm

##### Supply Pressure Effect

Less than 2% of span (change of output for supply change from 18 to 22 psig)

##### Temperature Range

-40 to 180°F (-40 to 85°C)

##### Electrical Connections

Enclosed terminal block, 1/2" threaded

##### Enclosed

NEMA 3R  
NEMA 4 via conduit vent

##### Electrical Classification

FM Approved  
Series 771\_ \_ \_ F1: Intrinsically safe for Class I/II/III, Div. 1, Groups A, B, C, D, E, G when used with approved barriers and converters listed on Moore drawing #15032-7704/7705, and when installed per manufacturer's instructions.

Series 771\_ \_ \_ F2: Non-incendive for Class I, Div. 2, Groups A, B, C, D. Dust-ignition proof for Class II, Div. 1, Groups E, G. Suitable for Class III, Div. 1 hazardous locations.

### Performance Specifications

#### Calibration Accuracy

± 1/2% of span standard unit  
± 1% of span boosted unit

#### Reproducibility

0.2% of span

#### Response Level

0.025% of span

### Model Number

Current-to-Pneumatic  
Transducer

#### Exhaust

- Atmospheric
- Tapped Exhaust

#### Input/Output

Input Range <sup>1</sup> (mA dc)	Output Range (psig)	Input Impedance (Ohms)
1 to 5	3 to 15	2450
0 to 4	3 to 15	2450
4 to 20	3 to 27	610
4 to 20	3 to 15	185
10 to 50	3 to 15	30

#### Intrinsically-Safe Designation

- Intrinsically Safe (omit for other classifications)

#### Accessories

- Reverse Acting Output

### Order No.

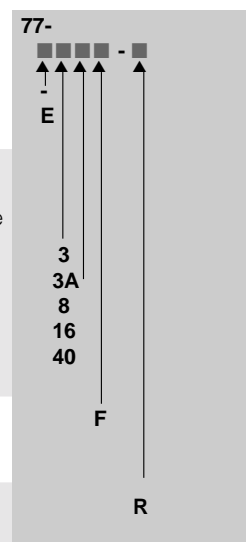

1) Other input ranges available; 0 - 3 mA to 0-2500 mA.

# Transducers

## Models 77 and 771 Current-to-Pneumatic Transducers

### Ordering data

#### Model Number

Order No.

Current-to-Pneumatic Transducer

#### Input/Output

Input Range <sup>1</sup> (mA dc)	Output Range (psig)	Input Impedance (Ohms)
1 to 5	3 to 15	2450
4 to 20	3 to 27	610
4 to 20	3 to 15	185
10 to 50	3 to 15	30

#### Output Capacity

- Boosted
- Standard

#### Options

- None Required
- Terminal Strip

#### Electrical Approval

- None Required
- Intrinsically Safe Class I, II, III Div. 1, Groups A, B, C, D, E, G
- Non-Incendive Class 1, Div. 2, Groups A, B, C, D. Dust-ignition proof Class II, Div. 1, Groups E, G. Suitable for Class III, Div. 1 hazardous locations

771-

■ ■ ■  
 ↑ ↑ ↑  
 3 8 16 40  
 B S  
 N T  
 N  
 F1  
 F2

#### Accessories

- ▶ P/N 12330-100 - Wall Mount Bracket
- ▶ P/N 12334-130 - Pipe Mounting Bracket
- ▶ Piped Airset
- ▶ Reverse Acting (not available on the Model 771-8)  
Increase input; decrease output. Add "R" to model number.

### Mounting Dimensions – Model 77

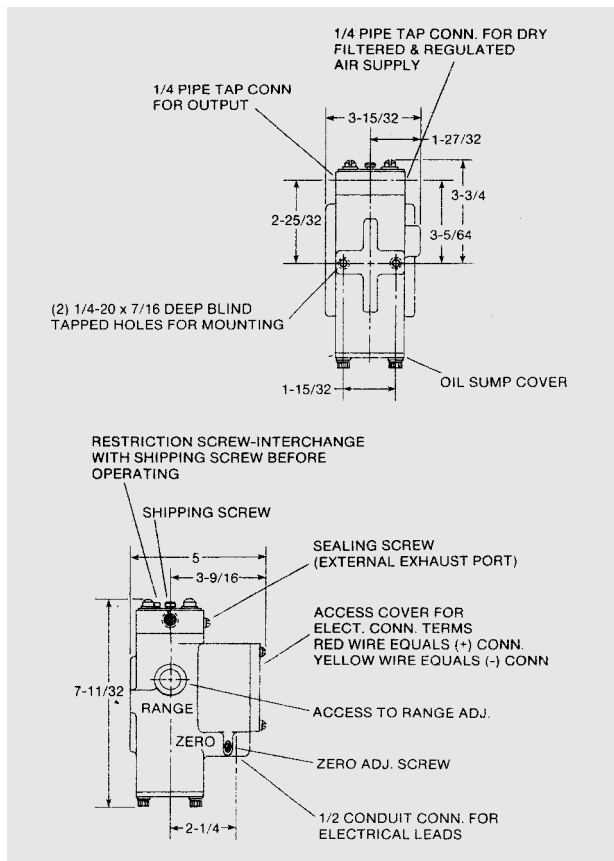

#### NOTES:

1. ALL CONNECTIONS ARE 1/4 NPT EXCEPT AS SHOWN.
2. MUST BE MOUNTED VERTICALLY ( $\pm 10^\circ$ ) AS SHOWN.
3. FLAT ADAPTER PLATE (P/N 12330-100) AVAILABLE TO MOUNT TRANSDUCER ON A BLIND WALL.

# Transducers

## Models 77 and 771 Current-to-Pneumatic Transducers

### Dimensional drawings

#### Mounting Dimensions – Model 771 S/B

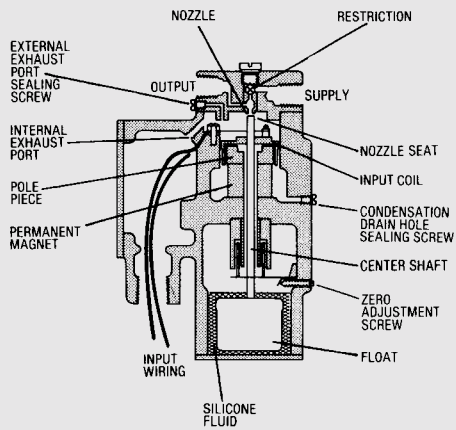

**MODEL SERIES 771S**  
Standard Output Capacity

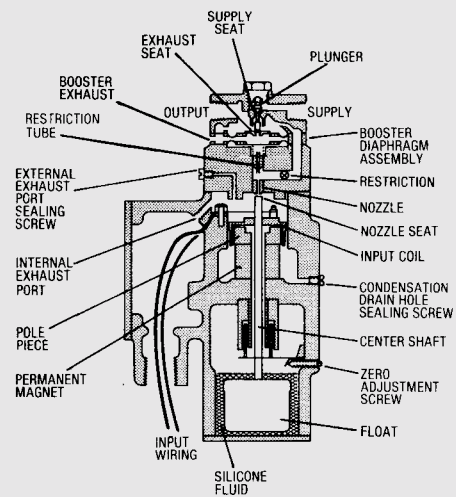

**MODEL SERIES 771B**  
Boosted Output Capacity

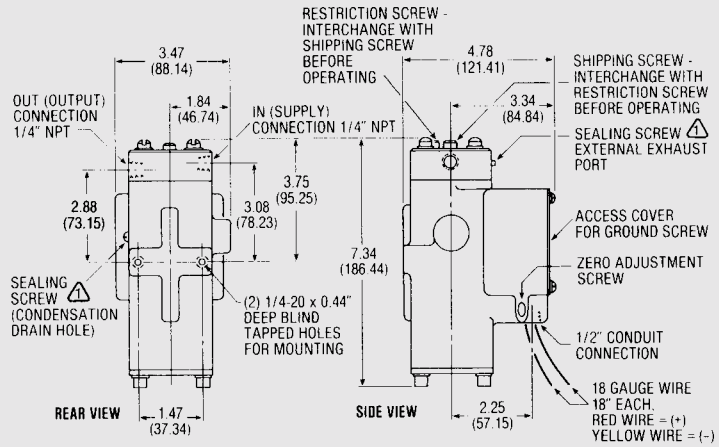

**MODEL SERIES 771S**  
Standard Output Capacity

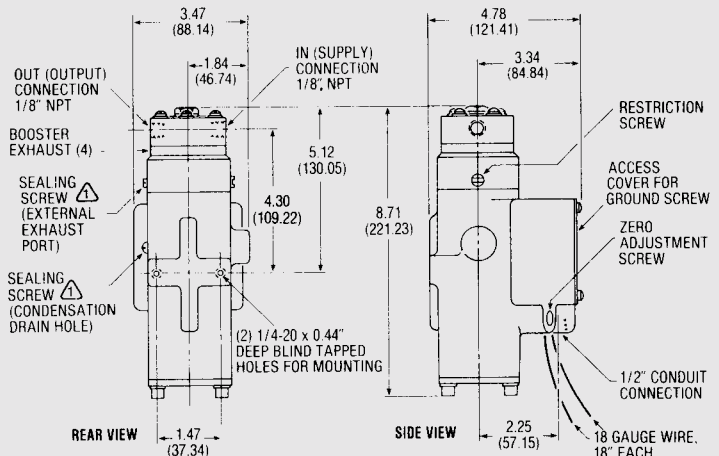

**MODEL SERIES 771B**  
Boosted Output Capacity

**NOTES:**

1. Sealing screw must not be removed in a Class II hazardous location or under any NEMA 4 condition.
2. Dimensions are shown in inches and (millimeters).
3. Clearance of at least 5" (127MM) must be left above the top when mounting the transducer to permit removal of shipping and restriction screws and top cap (standard capacity models) and retaining nut (boosted models).
4. Transducer must be installed so that water cannot enter booster exhaust under NEMA 4 conditions (boosted models).
5. Transducer must be installed within 10° of vertical.