

Product Data Sheet  
225DS-25d  
03/26/04

## 3808 MVT Multivariable Transmitter

### Model 3808-30A With DP/P/T Variables

#### Featuring:

- Excellent measurement performance over the full range of operating pressure and temperature conditions
- Extremely low power consumption—perfect for remote sites with battery and solar power systems
- “Bilingual” Networking via BSAP and Modbus protocols with RS 485 interface
- RS 232 port for configuration
- Analog output with FSK signal (alternative to RS 232/485)
- Intrinsically safe and explosion proof for operation in Class I Division 1 hazardous areas
- Bidirectional DP measurement
- DP/P “wet end” sensor assembly is independent of the “top end” assembly
- Simple calibration and configuration via web pages

#### INTRODUCTION

The 3808 MVT is Bristol Babcock’s answer to industry demands for a transmitter with high reliability, high performance over real world pressure and temperature conditions, ease in use, “networkability” and very low power consumption. The 3808 MVT has been designed to provide the highest value in terms of all user considerations, including purchasing, installation, operation and maintenance.

To maximize measurement accuracy, the 3808 combines a wet end with a low reference uncertainty of 0.075% URL, with a design that minimizes effects of pressure and temperature over the full range of operating conditions.

For remote sites such as those in the energy and water industries, power consumption has been a key consideration. Costs of batteries and solar panels are proportional to current draw and many users are surprised at the capital expenses associated with electronics, which have not been designed to conserve power. The sophisticated design employed by the 3808 MVT keeps current



**The Bristol Babcock 3808 MVT Multivariable Transmitter features accurate measurement of DP, gauge pressure and temperature.**

draw well below 2 mA and with a power source as low as 5 Vdc.

For remote sites, power budgeting is often very tight. Since the power consumption is so low, the 3808 MVT can even be added to existing sites, which were designed with no extra capacity for power.

While the BSAP protocol ensures compatibility with Bristol Babcock measurement and SCADA systems, Modbus provides compatibility with a wide variety of controllers, flow computers, RTU devices and SCADA systems from numerous suppliers.

#### FUNCTIONALITY OVERVIEW

The Bristol Babcock 3808 MVT provides the following basic operations:

- Conversion of sensor readings from the “wet end” DP/P sensor assembly into accurate floating point pressure values for DP and P. Conversion calculations utilize correction coefficients contained in the sensor assembly and are performed once per second for each process variable
- Conversion of raw readings from an on-board A/D into an accurate floating point RTD value. RTD conversions are performed once per second

- Up to 19200 baud, 2-wire RS-485 serial communications interface, or a 1200 baud, FSK modem interface via the 4-20ma current loop for Network communication
- Local RS-232 serial communications interface fixed at 19200 baud. (Connecting to the RS-232 communications interface disables the RS-485 communications)
- A subset of the Bristol BSAP RDB and Peer-to-Peer communications interface:
  - Complete set of User/Host Interface functions for Configuration, Calibration, and Data Collection
  - Floating point values returned individually, or in pre-defined Lists
  - Floating point values available for DP/GP, SP, T, Sensor Temperature, and Error Status
  - Floating point, Logical, or String values also available for other ST3808 user configuration parameters
- Optional, 4-to-20 mA Analog Output:
  - Linear or Square Root Mode
  - Reversible Output Action
  - May be controlled externally to provide a remote AO
- Optional, on-board LCD display with DP, P and T information

### PHYSICAL OVERVIEW

Service: Flow, level, pressure, temperature measurements for liquids and gases.

Diaphragm Material: 316 SS or Hastelloy C

Flange Material: 316 SS or Hastelloy C

Flange Bolt Material: 316 SS

Fill Media: DC 200 Silicone Oil

Process Connections: ¼" NPT on flanges 1/2" NPT with connection blocks.

Electrical Connections: ½" NPT Conduit Connection

Housing: Low Copper Aluminum with epoxy paint NEMA 4X explosion proof.

Local indication: 4-½-Digit LCD display linear or square root in engineering units.

RTD sensor: 3-wire platinum 100-ohm per DIN 43760 25 feet max.

User connections: 10-terminal (2-rows) tri-barrier strip for +power, -power, RTD+, RTD-, RTD-, TXD, and RXD.

### POWER SUPPLY INFORMATION

Operating Voltage Range: 5 – 42 Vdc

Current Draw:

With RS 485: Less than 2 mA

With FSK, but with 4–20 mA output disabled: Less than 3.2 mA

Turn-on time:

Measured input variables will be within specifications less than two seconds after power is applied to the 3808 MVT.

### ACCURACY AND PERFORMANCE SPECIFICATIONS

All specifications are for the digital, floating-point signal.

#### Differential Pressure and Static Pressure

Combined effects of nonlinearity, nonrepeatability and hysteresis at reference pressure and over the operating temperature range:

DP and SP linear mode:  $\pm 0.075\%$  of Calibrated Span or  $0.015\%$  of URL, whichever is greater.

Temperature effect on Static and Differential pressure:  $\pm 0.21\%$  URL maximum combined shift of zero and span with an ambient temperature change of  $60^{\circ}\text{C}$  ( $108^{\circ}\text{F}$ )

Static Pressure Effects On Differential Pressure:

Zero error:  $\pm 0.1\%$  URL, for a change in static pressure of 1000 psi

Span error:  $\pm 0.1\%$  reading, for a change in static pressure of 1000 psi

Long Term Stability at Constant Conditions:  $\pm 0.1\%$  URL/Year typical

Mounting position effect:  $\pm 2$  in H<sub>2</sub>O maximum, which can be calibrated out.

Power Supply effect:  $\pm 0.005\%$  of URL maximum for any change within specified input power supply voltage range.

Ripple and noise: Per ISA 50.1 Section 4.6

### Process Temperature - RTD Interface

A three-wire platinum RTD per DIN 43760 is supported. The temperature, T, in degrees Celsius is calculated using the Resistance vs. Temperature Tables according to the DIN EN 60751 standard for Class A & B RTDs. The DIN EN 60751 equation is:

$$R(t) = R_0 * (1 + At + Bt^2)$$

Where:

$$A = 3.9083 * 10^{-3} \text{ } ^\circ\text{C}^{-1}$$

$$B = -5.775 * 10^{-7} \text{ } ^\circ\text{C}^{-2}$$

$$R_0 = 100\text{ohms}$$

In addition, the user may enter the R<sub>0</sub>, A, and B coefficients of a custom calibrated RTD, another platinum standard or a different material (Nickel, Balco or Copper). During the RTD calibration, the User will be able to set the R<sub>0</sub>, A, and B coefficients, restore the factory default for these coefficients, and calibrate the internal Reference resistor.

**Process Temperature Input Specifications** (for the interface, only, not including the RTD probe or wiring)

RTD Conversion Accuracy:  $\pm 0.1^\circ\text{C}$ , or  $\pm 0.1\%$  of reading, whichever is greater

Ambient temperature effect on RTD measurement:  $\pm 0.01^\circ\text{C} / ^\circ\text{C}$  max

Long Term Stability at Constant Conditions:  $\pm 0.25^\circ\text{C} / \text{month}$  max

### Analog Output Specifications

Non-linearity: 0.1% max

Temperature effects:  $\pm 0.25\%$  Full Scale over 60 degrees C.

### ENVIRONMENTAL SPECIFICATIONS

Over Pressure Limit: Equal to the static pressure upper range limit (URL).

Temperature limits:

Wet End:  $-40$  to  $+85^\circ\text{C}$

Electronics:  $-40$  to  $+85^\circ\text{C}$

With Display:  $-30$  to  $+70^\circ\text{C}$

Storage Temperature:  $-40$  to  $+100^\circ\text{C}$

Humidity limits: When covers are properly installed, unit will withstand 0 to 100% RH (NEMA 4X enclosure)

Vibration:  $\pm 0.1\%$  URL/g max 10-500 Hz in any axis per SAMA PMC-33-1C

Electromagnetic compatibility:

Conditions: Current output (only) twisted pair wires includes RTD. Covers installed and wiring run in grounded conduit. 10V/M, 20-500 MHZ per SAMA PMC-33-1C:

DP and SP:  $\pm 0.25\%$  URL

RTD Temperature:  $\pm 1^\circ\text{C}$

### LIQUID CRYSTAL DISPLAY (LCD)

The LCD displays the measured variables for DP, P, and T. The display will continually cycle through all measured variables. The value and Engineering Units for a particular variable will be displayed for three seconds. An annunciator indicates which pressure variable is being displayed.

The LCD provides 4 1/2 digits of display precision with a decimal point. The following Engineering Units are included:

- °C
- °F
- BAR
- psi
- in H<sub>2</sub>O @ 60°F
- kg/cm<sup>2</sup>
- kPa

### WEB USER INTERFACE FOR THE 3808 MVT

A variety of User Interface features are provided by the 3808 MVT. These include:

- Set Communications Baud Rate
- Set BSAP Local Address
- Set BSAP Group Number
- Set Modbus Node Address
- Set Modbus Mode (ASCII/RTU)
- Enable/Disable Static Pressure Reading
- Enable/Disable RTD Temperature Reading
- Read current DP/GP, SP, T, Sensor Temperature, and Status values
- Read DP/GP and SP Upper Range Limits
- Calibrate Zero/Span for DP/GP and SP
- Calibrate Zero for RTD
- Configure RTD Coefficients
- Configure 4-20mA Analog Output
  - Enable/Disable
  - Select Linear/Square Root Mode
  - Select Forward/Reverse Acting
  - Select Output Variable (DP/GP, SP, User Defined, or None)
  - Calibrate Zero/Span
- Select Engineering Units for DP/GP, SP, T
- Set Floating Point Damping Factor
- Display Transmitter Information (Traceability information, Range Codes, Firmware Revision)

### COMMUNICATION INTERFACE

#### BSAP INTERFACE

The 3808 MVT will act as an immediate response BSAP Slave device. The 3808 MVT will function as a terminal node only in a BSAP Network. BSAP Global messages received with the 3808 MVT's Local Address will be processed by the 3808 MVT. Note that pass through, or routing, of BSAP Global messages, Expanded BSAP messages, and TimeSync/Node Routing Table messages are not supported.

A subset of the RDB and Peer-to-peer messages are supported. This will provide the user both RDB and Peer-to-Peer List access to the 3808 MVT Process variables and parameters. The following items are available via RDB Requests:

- Differential/Gauge Pressure
- Differential/Gauge Pressure Upper Range Limit
- Static Pressure
- Static Pressure Enable/Disable
- Static Pressure Upper/Lower Range Limit
- RTD Temperature
- RTD Temperature Enable/Disable
- Sensor Temperature
- Error Code
- BSAP Local Address
- Modbus Node Address
- Baud Rate
- Firmware Version
- Sensor Number
- Transmitter Number

#### MODBUS INTERFACE

The 3808 MVT will act as a Modbus compatible, slave device. The 3808 MVT provides support for both Modbus ASCII and Modbus Remote Terminal Unit (RTU) transmission modes, utilizing a subset of the Read/Write commands available via Modbus.

To provide support for a variety of Modbus compatible host controllers, the 3808 MVT data available via Modbus are mapped into Modbus Coils/Registers. To accommodate the different types of Modbus hosts available (i.e. standard Modbus, ENRON Modbus) floating point data items are mapped to several different Modbus Register address ranges. This provides both 16-bit and 32-bit

register access using the appropriate register address and function code.

The following Modbus Function Codes are supported:

<u>Code</u>	<u>Description</u>
1	Read Coils
2	Read Input Registers
3	Read Holding Registers
4	Read Input Registers
5	Force Single Coil
6	Preset Single Register
15	Force Multiple Coils
16	Force Multiple Registers

The data type associated with a specific Read/Write request is identified by the Coil/Register Address contained in the message.

The following is the Modbus Mapping for Coils:

<u>Address</u>	<u>Attributes</u>	<u>Description</u>
0001		unused
0002	RW	Master Reset
0003	RW	Calibration Mode
0004	RO	RTD present
0031	RW	DP/P, Reset Factory Calibration
0032	RW	SP, Reset Factory Calibration
0033	RW	T, Reset Factory Calibration

The following is the Modbus Mapping for the 32-bit Floating Registers:

<u>Address</u>	<u>Attributes</u>	<u>Description</u>
7401	RO	Differential/Gauge Pressure (DP/P)
7402	RO	Static Pressure
7403	RO	Process Temperature (T)
7404		unused
7405		unused
7406		unused
7407	RO	DP/P Upper Range Limit
7408	RO	DP/P Lower Range Limit
7409	RW	DP/P Upper Operating Limit
7410	RW	DP/P Lower Operating Limit
7411	RO	SP Upper Range Limit
7412	RO	SP Lower Range Limit
7413	RW	SP Upper Operating Limit
7414	RW	SP Lower Operating Limit
7415	RO	T Upper Range Limit
7416	RO	T Lower Range Limit
7417	RW	T Upper Operating Limit
7418	RW	T Lower Operating Limit
7419	RW	DP/P Calibrated Zero
7420	RW	DP/P Calibrated Span
7421	RW	DP/P Floating Point Damping Factor
7422	RW	SP Calibrated Zero
7423	RW	SP Calibrated Span
7424		unused
7425	RW	T Calibrated Zero
7426	RW	T Calibrated Span
7427		unused
7428	RW	User Entered value for Process Temperature
7429	RO	Sensor Temperature

### ORDERING INFORMATION – USER SOFTWARE AND ACCESSORIES

Bristol Babcock Web Pages and OpenBSI/LocalView – Calibration and configuration software for a PC  
CD part number: 395575-02-8

PC-to-3808-MVT Cable – Connects to the RS 232 port on the 3808 MVT, 10 foot, part number: 396596-01-0

Transmitter Interface Unit (TIU) – For compatibility with the 3508, this module is used to connect a PC to the FSK signal on the 3808 MVT.  
Part Number 389959-01-4

For the TIU, please specify the modem cable length:

6 foot – part number 390929-01-8  
12 foot – part number 390929-02-6  
25 foot – part number 390929-03-4

### APPLICATION EXAMPLE – 4 RUN NATURAL GAS METERING STATION

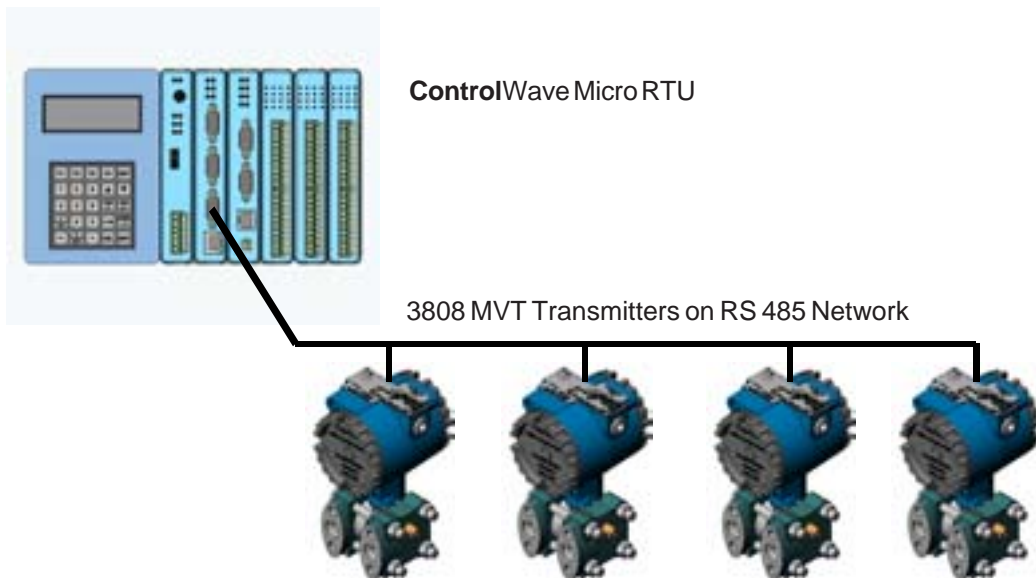

**U.S.A.**  
**Bristol Babcock Inc.**  
1100 Buckingham St.  
Watertown, CT 06795  
Telephone: (860) 945-2200  
Fax: (860) 945-2213

**U.K.**  
**Bristol Babcock Ltd.**  
Blackpole Road  
Worcestershire, DY11 7QP., England  
Telephone: 44-(0)-1905-856950  
Fax: 44-(0)-1905-856969

**Canada**  
**Bristol Babcock Canada**  
234 Attwell Drive  
Toronto, Ontario M9W 5B3  
Telephone: (416) 675-3820  
Fax: (416) 674-5129

DESCRIPTION			CODE
A B C	Input Range Differential (inH2O)	Static Pressure (PSI)	A B C
10	0-7.5 to 0-150	1000	1 2 1
	0-7.5 to 0-150	2000	1 2 2
	0-7.5 to 0-150	500	1 2 3
	0-5 to 0-100	2000	1 3 2
	0-15 to 0-300	1000	1 4 1
	0-15 to 0-300	2000	1 4 2
	0-1.25 to 0-25 PSID	2000	2 0 2
<b>D</b>	<b>Diaphragm Material</b>		<b>D</b>
	316 Stainless Steel		1
20	Hastelloy C		2
<b>E</b>	<b>Filling Media</b>		<b>E</b>
30	DC 200 Silicone		1
<b>F</b>	<b>Flange Material</b>		<b>F</b>
	316 Stainless Steel	Match D - diaphragm material	1
40	Hastelloy C		2
<b>G</b>	<b>Flange Vent Valve</b>		<b>G</b>
	None		0
50	With Vent Valve - 316 SS	Match D and F, diaphragm and flange materials	1
	With Vent Valve - Hastelloy C		2
<b>H</b>	<b>Manifold Adapter</b>		<b>H</b>
	None	Match D and F, diaphragm and flange materials	0
60	Stainless Steel		1
	Hastelloy C		2
<b>J</b>	<b>Comm / Output Options</b>		<b>J</b>
	4-20 mA current output / FSK	<i>Note: Local calibration requires TIU.</i>	1
70	RS 485	<i>Note: Local calibration requires RS 232 cable.</i>	2

Model specification is continued on the next page.

# Bristol Babcock

## 3808 MVT Multivariable Transmitter Model 3808-30A With DP/P/T Variables

Product Data Sheet  
225DS-25d  
03/26/04

	DESCRIPTION	CODE
<b>K</b>	<b>Local Indication</b>	<b>K</b>
	None	0
80	4 1/2 Digit LCD	1
<b>L</b>	<b>Flange Orientation</b>	<b>L</b>
	Standard (faces away from front)	1
90	90 degrees (down)	2
	Note: Housing is very easy to rotate 180 degrees around in the field.	
<b>M</b>	<b>Mounting Bracket</b>	<b>M</b>
	None	0
100	With "L" Flanged Mounting Bracket	1
	Not avail. with 90 deg. (down) flange orientation (Option K=2)	
	With Neck Mounted Bracket	2
	Available with any flange orientation	
<b>N</b>	<b>Certification</b>	<b>N</b>
110	UL/CUL Class I, Division 1, Groups C & D; Class I, Division 2, Groups A,B,C,D	1
<b>P</b>	<b>Warning Plate</b>	<b>P</b>
	None	0
120	Russian	1

### DIMENSIONED DRAWINGS

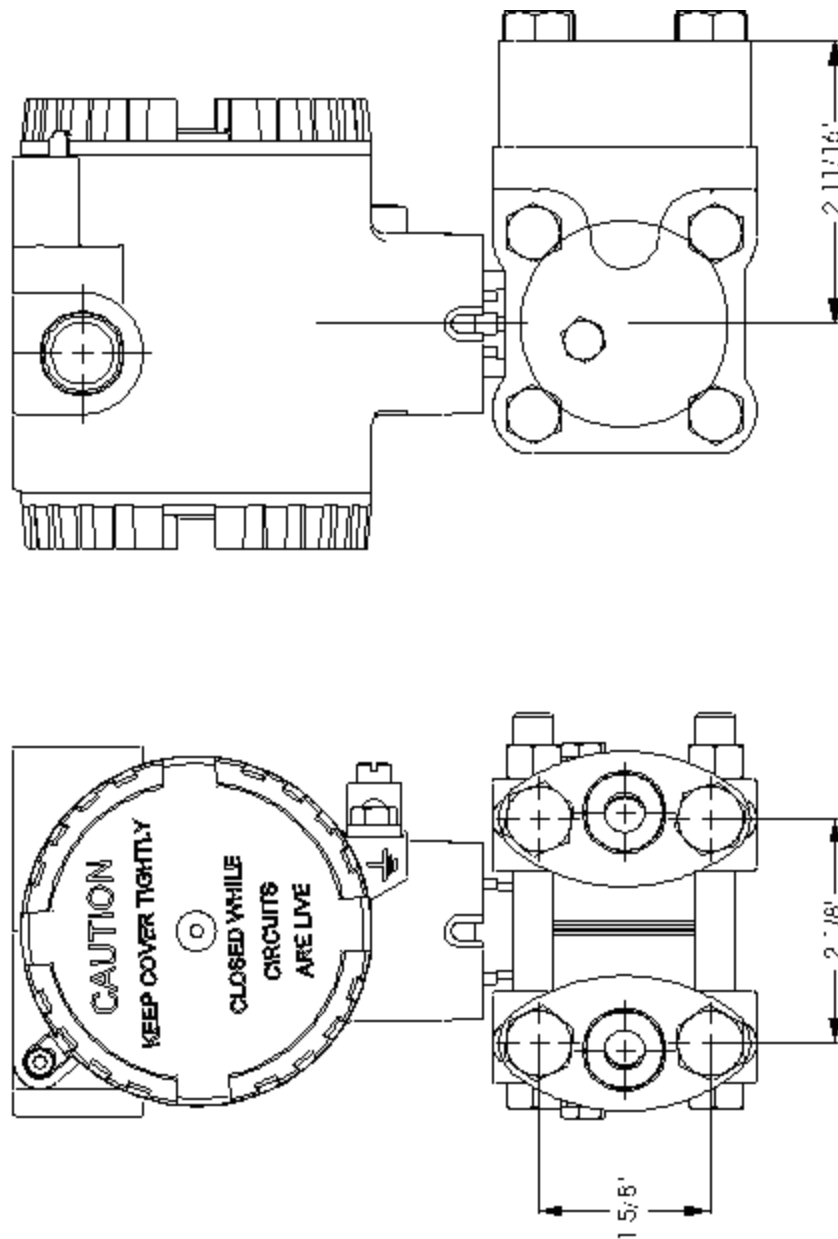

3808 MVT with Manifold Adapters Shown

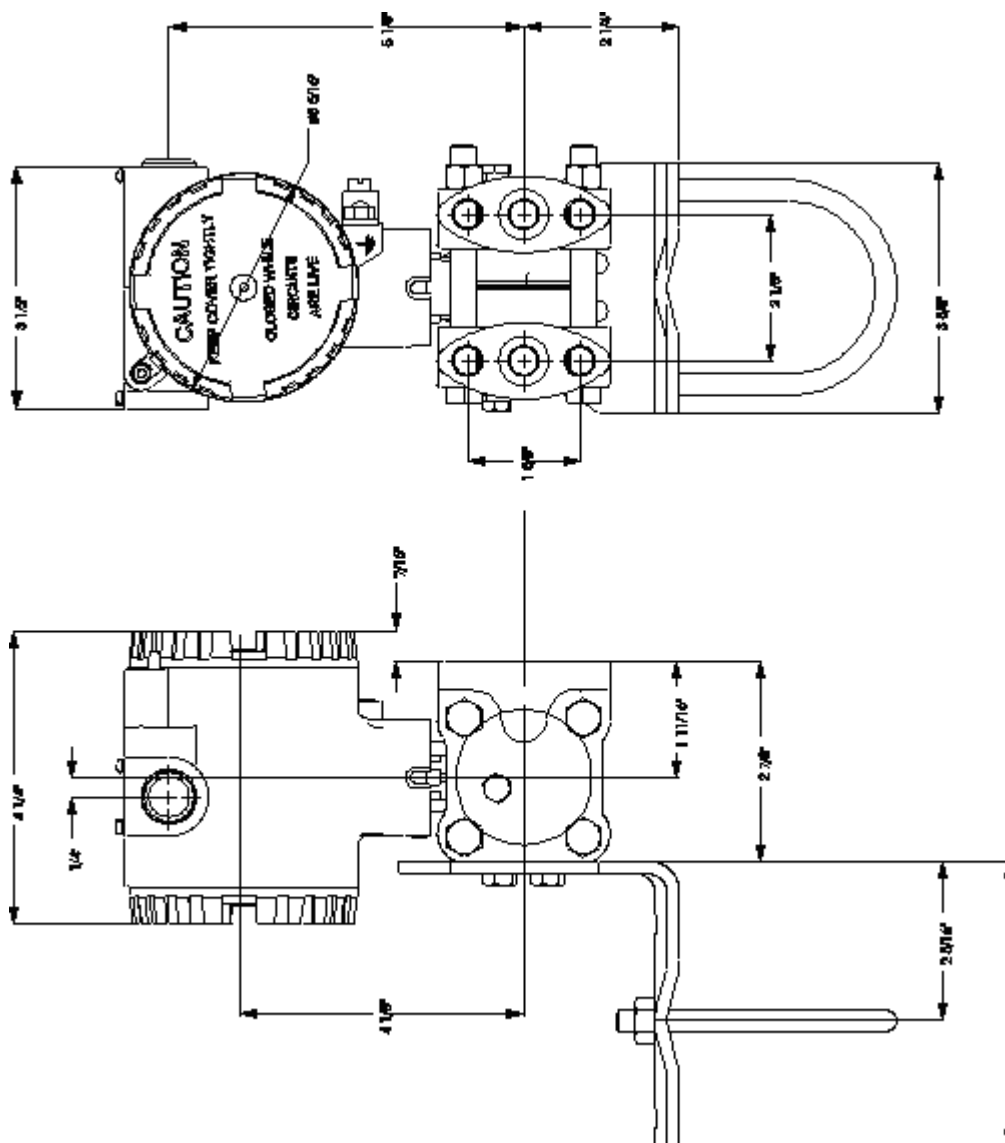

3808 MVT with "L" Flanged Mounting Bracket

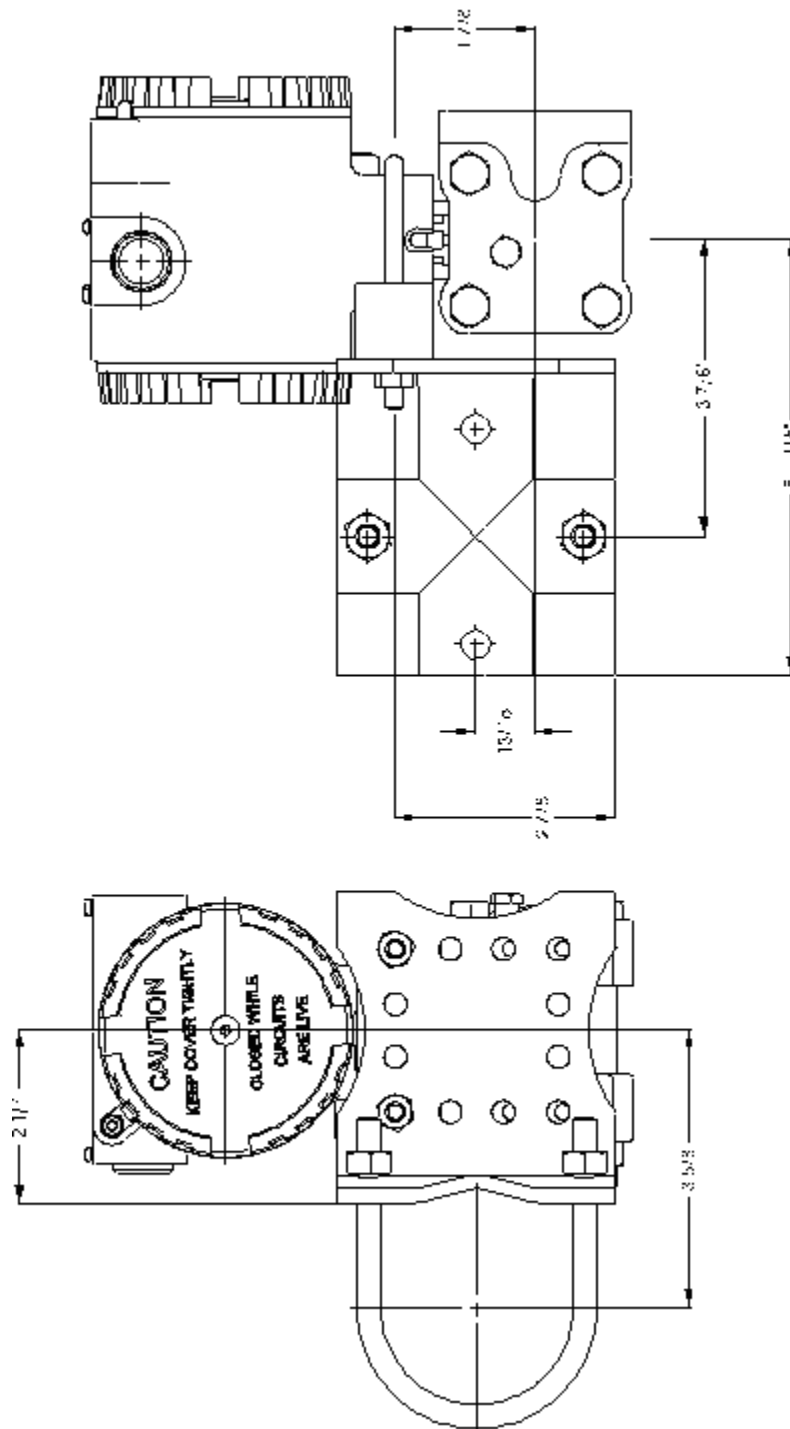

3808 MVT with Neck Mounted Bracket

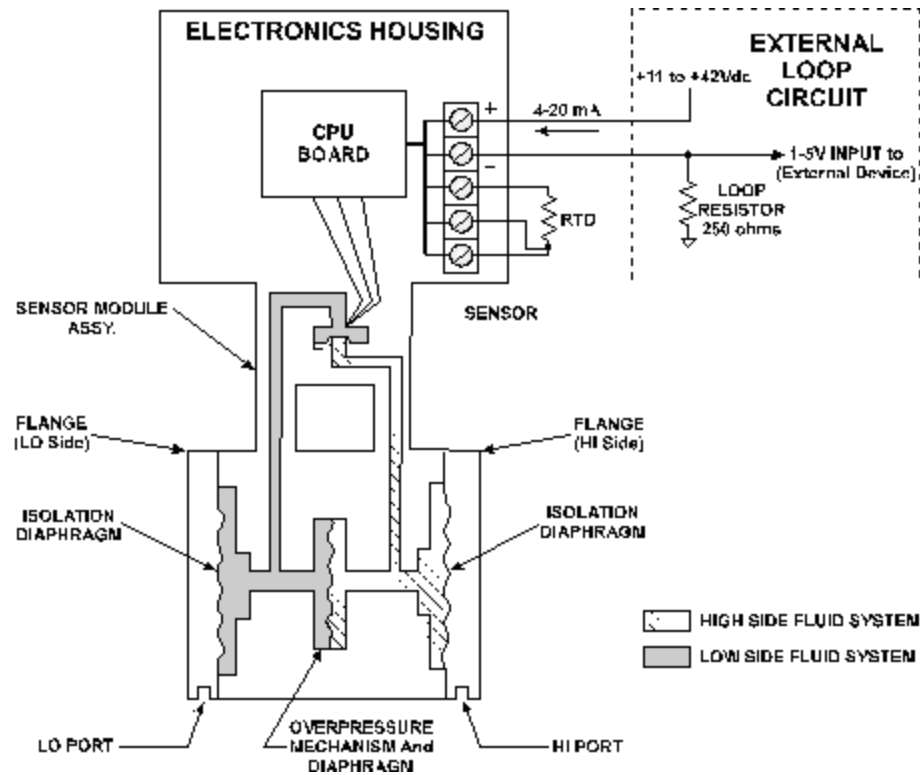

Simplified Diagram of 3808 MVT with 4 – 20 mA Signal

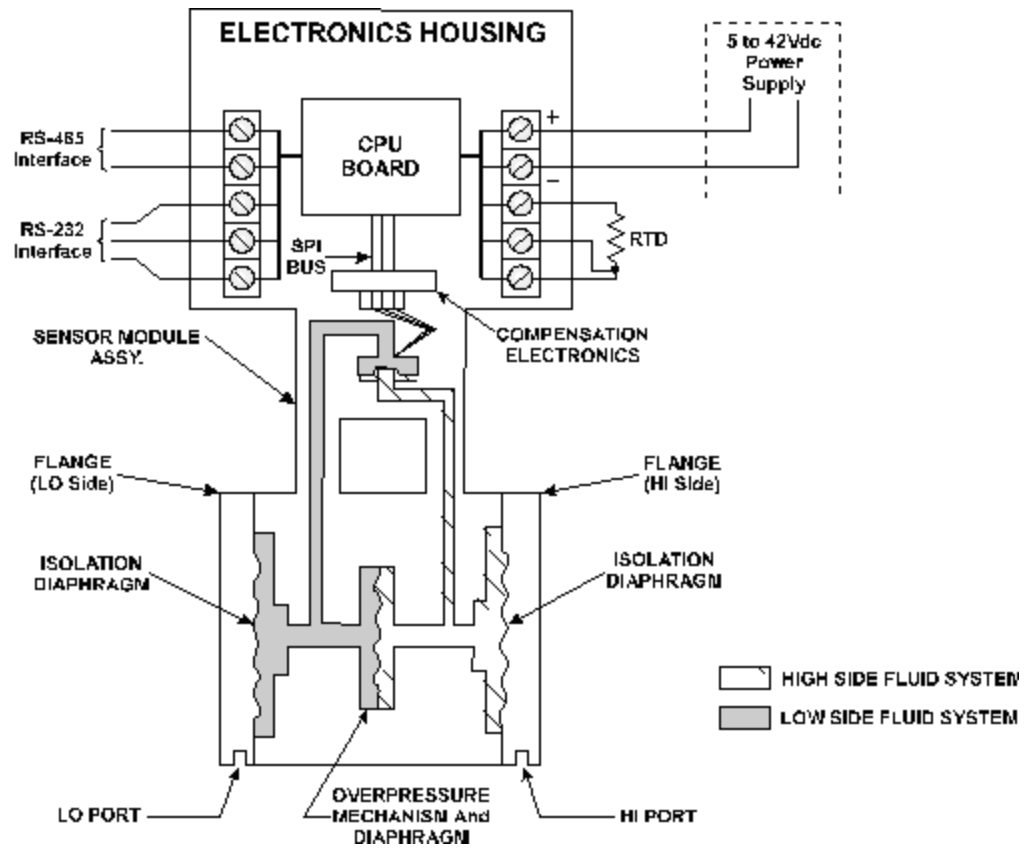

Simplified Diagram of 3808 MVT with RS 232 and RS 485 Interface

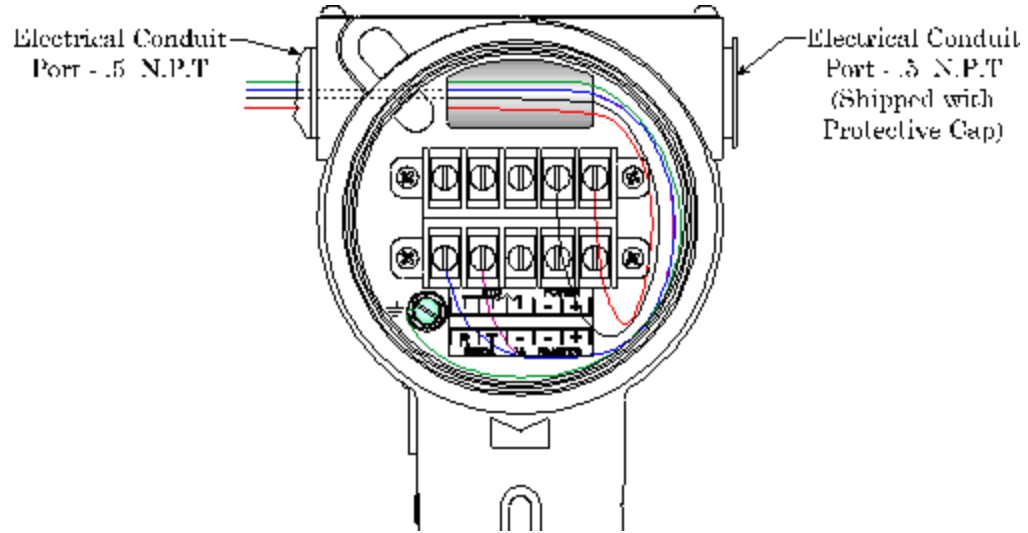

3808 MVT Wire Routing

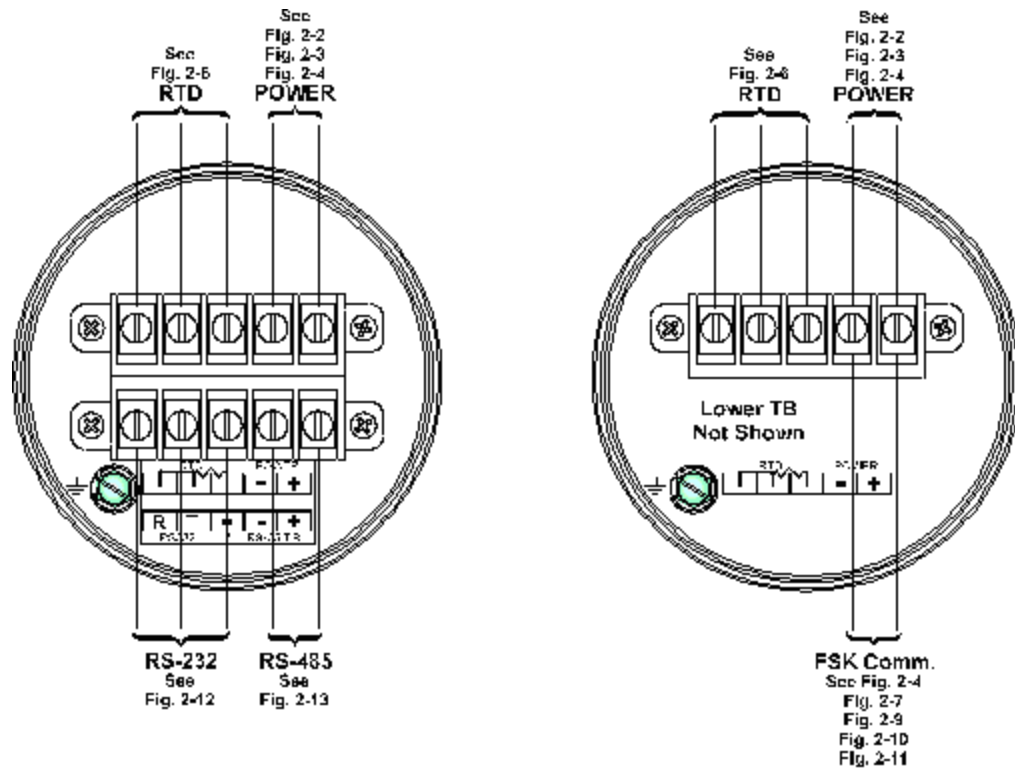

3808 MVT DIGITAL MODEL

3808 MVT ANALOG MODEL

3808 MVT Terminal Block Assignments