



Max Machinery Inc.

Call Max today...  
(707) 433-7281

## Model 215 Piston Meter

### SPECIFICATIONS

- **Flow range at (3 cps):**  
0.075 to 40 liters/min (10 gpm)
- **Maximum Operating Pressure:**  
70 bar (1000 psi) - standard  
210 bar (3000 psi) - optional
- **Displacement:** 47.6 cc/rev (2.91 in<sup>3</sup>/rev)
- **Weight:** 10 kg (22 lbs)
- **Recommended Filtration:** 10 micron (1250 mesh)
- **Port Size:** ½" NPT - Standard, #8 SAE - optional
- **Fluids:** Most non-aqueous, organic liquids
- **Heat Trace:** Fluid ports - optional
- [Go to Linearity Curve](#)
- [Go to Viscosity / Pressure drop curve](#)
- [Go to Output Signal choices \(Transmitters\)](#)

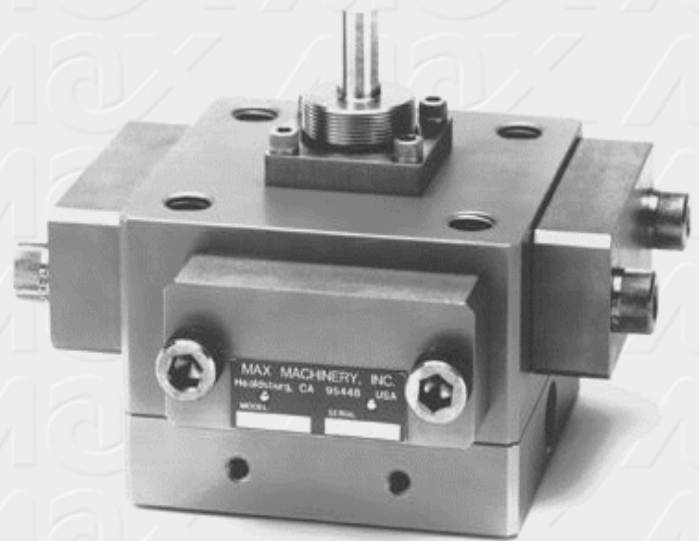

### MATERIALS OF CONSTRUCTION

- **Body:** Stainless Steel, type 303
- **Pistons:** Stainless Steel, type 303
- **Crankshaft:** Stainless Steel, type 303
- **Bearings:** Stainless steel, type 440C
- **Seals:** Viton® "O"- rings - Standard  
Teflon®, Neoprene, Nordel®, Buna N Seals - optional

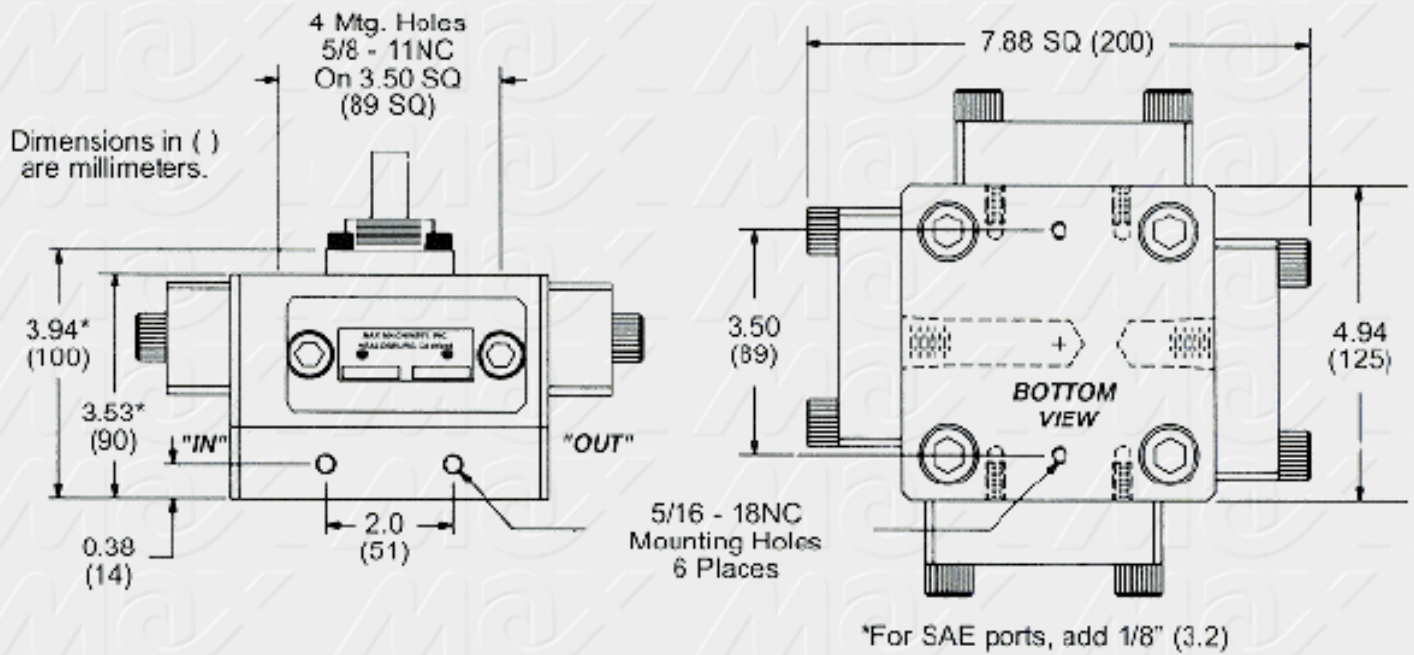
**PHYSICAL DIMENSIONS**

Max Machinery Inc., 1420 Healdsburg Ave., Healdsburg, CA 95448 USA

Phone: (707) 433-7281 Fax: (707) 433-0571

All pages and graphics Copyright© 1998 Max Machinery Inc.

Nordel® and Viton® are registered trademarks of DuPont Dow Elastomers.

Teflon® is a registered trademark of DuPont.